

Step Light

PSLS PSLES PSLLS

PSLS-PSLES-PSLLS

DESCRIPTION

Step Light (square).

SPECIFICATION

20 - 20 watt MR16 lamp.

LED - LED 48MODWH 12 volt DC.

CONSTRUCTION

Manufactured in New Zealand from the highest grade materials. Flush lens from fully tempered and ground glass. Lamp supported by S/S spring for easy changing and connected with nickel contact lamp holder with Teflon jacket connector leads.

Unique non wicking leak proof construction.

MOUNTING

PCAN allows fixing to concrete boxing or screw mount flanges available.

Patent- 532578

WARRANTY

- 316 Stainless Steel (SS) - 20 year warranty.
- Solid Copper (CO) - 20 year warranty.
- Black anodised (BL) - 5 year warranty.
- Matt anodised (MA) - 5 year warranty.
- * Each lens ring is engraved with the date of manufacture.

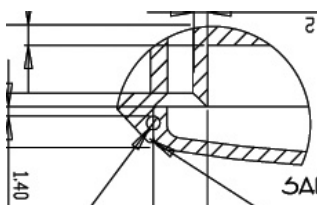
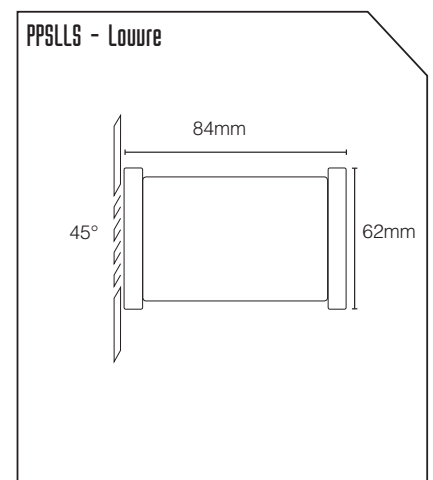
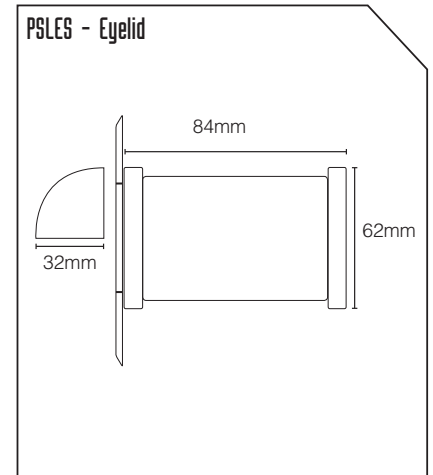
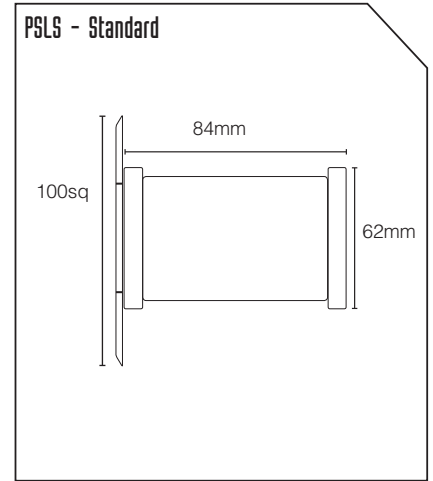

SALEPRO

SALES & PROMOTIONS. YOUR LIGHTING SPECIALISTS

